

Optimal processing

COPY JOGGER

Through aerating and knocking up paper stacks to flush the edges the Copy Jogger ensures their ideal processing with the Copy Binder.

Before feeding paper into printing, binding, folding, enveloping and other machines, it is advisable to use the Copy Jogger. It helps you process paper with an optimal result, guaranteeing trouble-free production runs.

- Continuously, adjustable and flexible at use
- The jogging box holds paper stacks of up to 1,000 sheets of DIN A4
- Also thin paper stacks and paper qualities can be knocked up thanks to adjustable panels
- Adaptable for paper stacks of sizes larger than DIN A4

COPY SILICONE OIL

For the oiling of spindles and bearings. Prevents the sticking of adhesives, builds a protective film on cutting tools.

COPY CLEANER

For removing adhesive residues and general dirt. The cleaner can be used for all Planax devices.

Specially developed for

COPY BINDER



PLANAX

COPY BINDER

COPY STRIPS

COPY JOGGER

Product overview

It is the binding that counts.

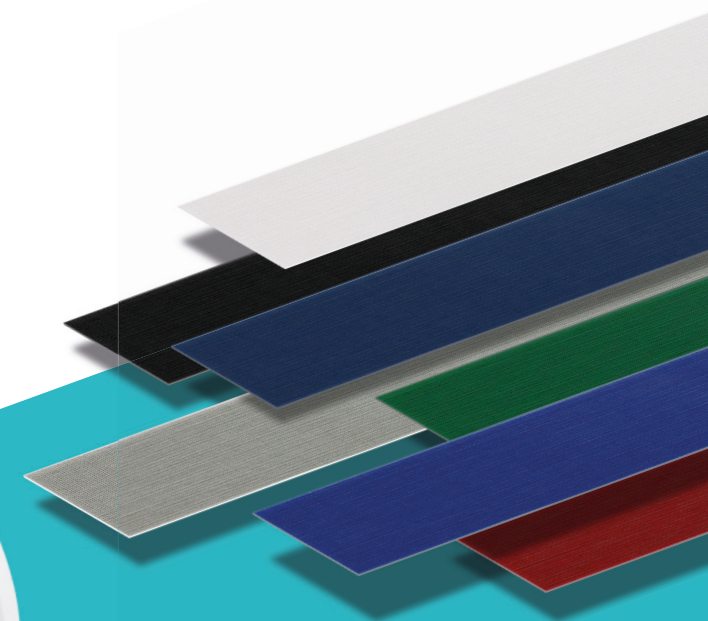

PLANAX

Planatol Coating GmbH

t +49 8031.720-0

f +49 8031.720-126

info@planatol-coating.de

planatol-coating.de

planatol-coating.de

Made in
Germany

Bookbinding quality

COPY BINDER

Turn your copies and printouts in no time to representative, high-quality documents – precise, clean and solid.



You require:

The Copy Binder, the thermo binding strips in high-quality linen and the cooling tray.

With its outstanding processing qualities, easy handling and economical consumer material, the Copy Binder is the ideal solution for offices, copy shops, tax consultants, auditors, etc.

Your benefits:

- Compact design and easy handling
- Perfect binding for 5 to 330 sheets (without cover)
- Fast, precise and neat processing
- Exact edges for a professional image
- Excellent layflat performance for easy reading
- High binding durability and stability
- Excellent stacking ability for trouble-free storage
- Compact form for easy enveloping and mailing

Quick and easy binding in three steps

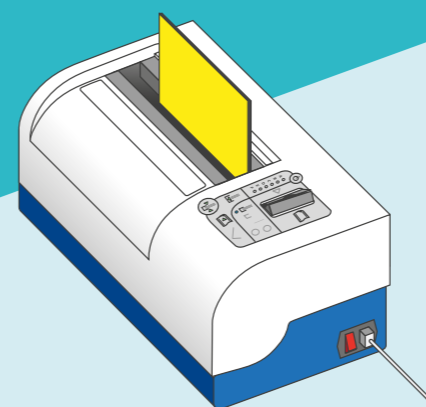

- 1** Insert loose pages.
Strip width is displayed.

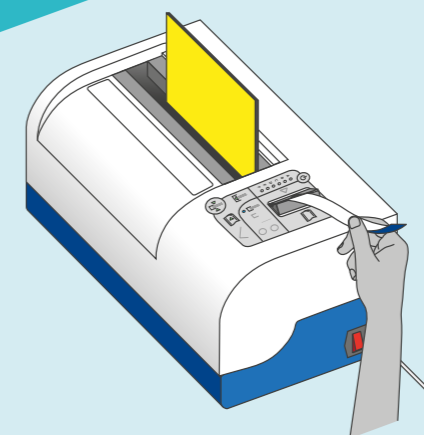

- 2** Insert Planax strip.
Binding process starts.

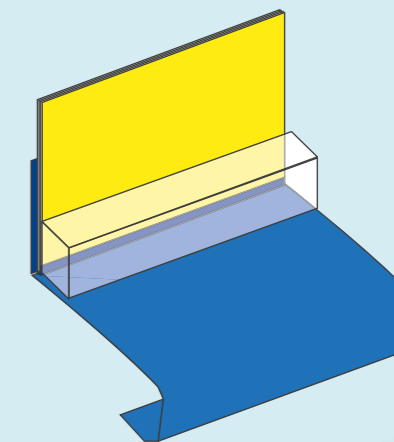

- 3** Take bound product and place in the cooling tray. Done!

COPY STRIPS

We have a wide range of binding accessories for the individual design of your bound products.

Use high-quality 100% linen thermal strips as spine, available in DIN A4, DIN A5, 11", 6 widths and 7 colours. The technical data of the device can be found on our website. Modifications in construction and design are reserved.

A4/A5 and 11"

- A / 20 mm
- B / 25 mm
- C / 30 mm
- D / 35 mm
- E / 40 mm
- F / 50 mm

Colours

- dark blue
- red
- grey
- green
- blue
- white
- black

